

# ADV63-125-12

## *Hybrid Universal Analog Digital Voltage Regulator Operation Manual*



Automatic Voltage Regulator for use in Brush-less, PMG and  
Auxiliary Winding Generators

## 1. SUMMARY

The ADVR63-125-12 is a totally new hybrid 12 Amp universal voltage regulator with a comparable footprint as the Basler\* AVC63-12 and AVC125-10, CAT\* VR6, KATO\* K65-12B and K125-10B, and the Leroy Somer\* 202-8634, and many other. To simplify installation, voltage sensing without PT's up

to 520 volts was added, also new DIP & TRIM adjustment compatible with many automatic paralleling and PF controllers in the market. The new CPU design makes the ADVR63-125-12 exceedingly stable, however keeping the analog power circuit for fast response.

## 2. SPECIFICATION

### Sensing Input 1Ø

Voltage 220 / 440VAC 50 / 60Hz  
(SW5 Selectable)  
180 ~ 260VAC @ 220VAC  
330 ~ 520VAC @ 440VAC

### Power Input 1Ø or 3Ø

Voltage 100 ~ 300VAC, 40 ~ 500Hz  
Output 63VDC @ 110VAC input  
125VDC @ 220VAC input

### Output

Current Continuous 12ADC  
Maximum 25ADC for 10 sec

### Frequency

50 / 60Hz (SW4 Selectable)  
40 ~ 51Hz @ 50Hz Preset 47Hz  
50 ~ 61Hz @ 60Hz Preset 57Hz

### Voltage Regulation

< ± 0.5% ( with 4% engine governing )

### Voltage Build-up

Residual voltage at AVR terminal > 6 VAC @ 25Hz

### Thermal Drift

0.03% per °C change in AVR ambient

### Over Excitation Protection

60% of Input Voltage

### External Volts Adjustment VR

10K ohm 0.5 watt trimmer

### Excitation Resistance

> 10 ohm

### Current Compensation

1 or 5A > 0.2VA  
Max ±7% @ P.F ±0.5

### Analogue Voltage Input

Un0 ~ 10% @ ±5VDC <2mA

### Respond Time

< 1 Cycle

### Unit Power Dissipation

Max. 12 watt

### Dimensions

214mm L \* 163mm W \* 45.7mm H

### Weight

1130g ± 2%

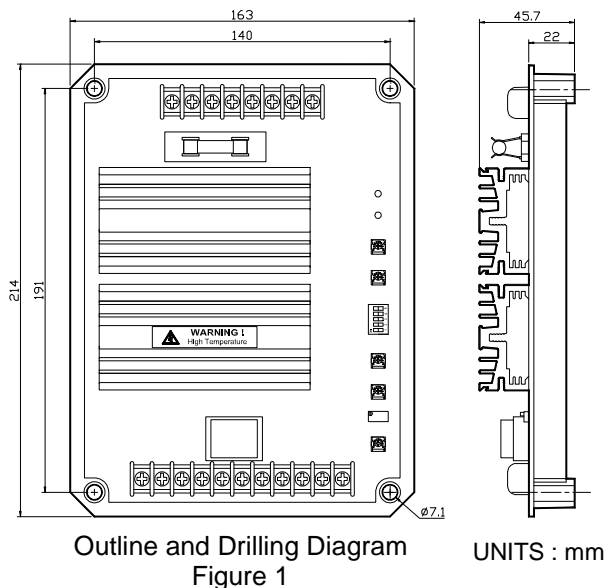

### ATTENTION

1. AVR can be mounted directly on the engine, genset, switchgear, control panel, or any position that will not affect operation. For dimension reference, please see Figure 1.
2. All voltage readings are to be taken with an average-reading voltmeter Meggers and high-potential test equipment must not be used. Use of such equipment could damage the AVR.
3. Secure all wiring connection. Do not install AVR at a place with high vibrations to prevent loose connections. For safety do not touch the heat sink while in operation.
4. Fuse specification : 12A / 250V slow blow type.

### 3. DIP SWITCH ADJUSTMENT (SW)

SW \ KW	<90KW	90~500KW	>500KW
1	OFF	ON	ON
2	OFF	OFF	ON

SW	ON	OFF
3	O/E Deactivated	O/E Activated
4	50Hz	60Hz
5	440V	220V

#### ATTENTION

When 60Hz frequency setting is selected on a 50Hz generator, it could result in under voltage.

When 50Hz frequency setting is selected on a 60Hz generator, it could result in over excitation current when stopping the generator and cause severe damage to the generator or AVR.

After adjusting SW1 or 2, the STAB must be recalibrated to ensure maximum performance.

All adjustment of SW must be conducted when engine is not in operation.

### 4. ADJUSTMENT

#### 4.1 VOLT

- Voltage setting adjusting the genset rated output voltage.
- When SW5 is "OFF" (220V) adjustable range is 175 ~ 260VAC.
- When SW1 is "ON" (440V) adjustable range is 350 ~ 520VAC.
- When terminal 7 & 4 are bridged together, voltage adjustment is on the AVR VOLT VR. When connect a 10k ohm external VR to terminal 7 & 6a the voltage adjustment can be adjusted remotely (When terminal 7 & 4 is open circuit the AVR VOLT VR is ineffective).

#### ATTENTION

AVR AC voltage readings are all average value.

#### 4.2 STAB

- Adjust STAB fully clockwise, the generator voltage will begin to fluctuate, whereas if adjust fully counterclockwise the voltage becomes stable.
- The correct stability setting is at a knee point, where the voltage is stable yet on the brink of becoming unstable.
- If Stability is over adjusted, it can result in high voltage fluctuation when load is connected.

#### 4.3 U/F

Under frequency protection adjustment. When generator frequency falls below the knee point, the under frequency protection circuit will begin to intervene and voltage and frequency begin to decrease in linear descend. Coordinate with the DIP switch SW4 frequency selection 50/60Hz.

When selecting 50Hz the adjustable range is from 40 to 51Hz and the factory presets at 47Hz.

When selecting 60Hz the adjustable range is from 50 to 61Hz and the factory presets at 57Hz.

#### 4.4 U/F LED

When under frequency protection is activated, the RED LED will light up.

#### 4.5 DIP

When under frequency protection is activated, the voltage droop ratio is adjusted via the DIP VR. The adjustable range is 3 ~ 10 V/Hz.

#### 4.6 DROOP

Droop adjustment. When paralleling, the AVR compensate the input rating and voltage shifting basis on load current, through internal circuit calculation and increase or decrease the voltage. When phase current lag the voltage, it decreases original voltage setting and if the phase current lead the voltage then it increases the original voltage setting. The increase and decrease range can be preset by the DROOP adjustment.

#### 4.7 TRIM

Analogue voltage Input sensitivity. When terminal 2 and 3 is added with a DC input (0 ~ ±5V), the TRIM is used to adjust the influence level from the DC input to the rated voltage. If the TRIM potential (POT) is adjusted fully counter-clockwise, and then the additional signal will not cause any influence. On the contrary if the TRIM is adjusted fully clockwise, then the additional signal will produce a maximum effect.

#### 4.8 O/E

The protection is enabled by selecting DIP SW 3 to OFF position (Protection disabled when DIP SW 3 select to ON). The O/E voltage setting is at 125VDC ±5V. If generator excitation voltage exceeds the setting the AVR will shutdown the excitation output and illuminate the O/E LED. To reset the protection, stop generator for 30 seconds before restart. The higher the excitation voltage the faster the AVR enables the protection from 0.1 ~ 20 seconds.

If O/E is disabled, (DIP SW 3 to OFF position) the AVR does not shutdown the generator excitation output but only illuminate the O/E LED.

## 5. CONNECTION TERMINAL

PIN NO.	NOTES
CH GND	Ground
2	Analogue voltage input
3	
4	For onboard voltage adjustment 4 & 7 Shorted For external voltage adjustment (Connect 10K ohm VR to 6a & 7) 4 & 7 Open
5	CT (Current Transformer) 1A input
5a	CT (Current Transformer) 5A input
6	CT (Current Transformer) common
6a	Bridge selection common
7	For onboard voltage adjustment 4 & 7 Shorted For external voltage adjustment (Connect 10K ohm VR to 6a & 7) 4 & 7 Open
8	Null
9	9 & 6a Open for single phase sensing
20	R phase sensing input
22	S phase sensing input
26	3Ø power input
28	1Ø or 3Ø power input
30	1Ø or 3Ø power input
F1	Positive + excitation output
F2	Negative – excitation output

### 5.1 Manual excitation / Field Flash (Non - PMG system)

If installing on a newly assembled generator, an exciter with incorrect polarity or with field residual voltage less than 6VAC, please disconnect the AVR wiring connections with engine at rest and follow the steps below:

- Series a limiting resistor at F1 (Positive) & F2 (Negative) and apply a DC input (Do not exceed 24VDC). The resistance is 1ohm per volt with 1 watt per volt at power.

For example : If the DC input is 24VDC with 24 ohms, the resistor should be rated 24 watts.

- Remove DC power input from the exciter after 5 seconds.
- Reconnect wiring.
- Start up engine, and if the measured residual voltage is still below 6Vac, repeat step 1 and 2.

### 5.2 Under frequency protection Knee point setting

50Hz adjustable range 40 ~ 51Hz  
Factory preset at 47Hz

60Hz adjustable range 50 ~ 61Hz  
Factory preset at 57Hz

#### Adjustment steps as follow :

- From DIP select generator frequency.
- Startup generator and adjust to rated speed.
- Adjust UF VR to maximum (Clockwise), adjust voltage to rated.
- Decrease engine speed to required knee point activation frequency.
- Slowly ad SW4 just UF VR counterclockwise until voltage begins to decrease (UF LED illuminates).

The under frequency protection only activate when generator frequency falls under the knee point setting, to prevent AVR from over excitation and causing damage. The V/Hz decrease margin is adjusted via DIP VR.

### 5.3 Wiring

#### 1. Power Input (26, 28, 30)

- Terminals 26, 28, 30 are for 3 phase power input and terminals 28, 30 are for single phase power input. The input voltage 100 ~ 300VAC, 40 ~ 500Hz from PMG, Auxiliary winding, generator power input.
- If a switch is required to shutdown the excitation output, add a switch at terminals 26, 28, 30 to shut down AVR power.

#### 2. Sensing Input (20, 22)

- 20, 22 are for single phase sensing input.
- In a single phase sensing input, terminals 9, 6a will need to be opened. Terminals 22, 24 need to be shorted and connect sensing input to terminals 20, 22, incorporating the DIP SW5 voltage setting.
- In a 220V SHUNT type generator, the power input and sensing input can be combined together.

### 3. Analogue Voltage Input (2, 3)

- Terminal 2 & 3 are Analogue Voltage Input, for connecting to remote voltage control (Paralleling Controller) of Var / PFC (Power Factor Controller).
- When TRIM is adjust to maximum, entering  $\pm 5VDC$  will effectively change the generator's rated voltage by 10%, and if adjust to minimum, the analogue voltage input becomes ineffective.

### 4. Droop Compensation (5, 5a, 6)

- When paralleling, connecting a N : 1A CT at terminal 5 & 6 or connection a N : 5A CT at terminal 5a & 6 enables DROOP VR to adjust the generator voltage droop rate (Adjust clockwise to increase).

The CT must never install on the same phase as the sensing input (Terminal 20 & 22).

- Circuit Voltage Compensation.

If CT input signal is reversed (K, L), it can become current compensation for the generator output, therefore the generator will voltage increase with the load current. The increase ratio is adjusted via the DROOP VR (Adjust clockwise to increase).

### 5. External VR (7, 6a)

- Terminal 4 & 7 must be shorted if external voltage adjustment is not required.
- When external voltage adjustment is required, connect one 10K ohm 1/2W VR to terminal 7 & 6a (The onboard VR then becomes ineffective).

### WARNING

Please make sure you have read and understand the contents of the instruction manual prior to installation. Incorrect wiring connection may result in irreversible damage to the product and other equipments.

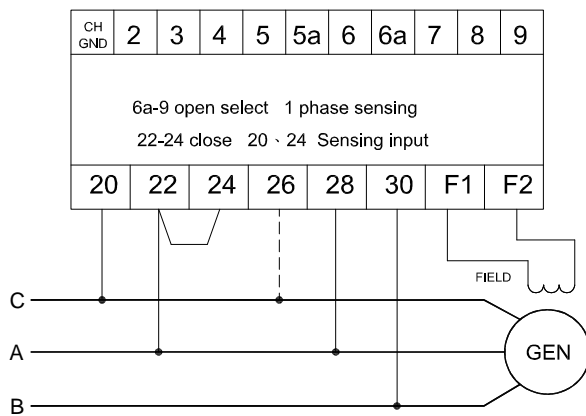

Figure 2 Single Phase Sensing  
22 & 24 Shorted, 20 & 22 Input (6a & 9 Open)

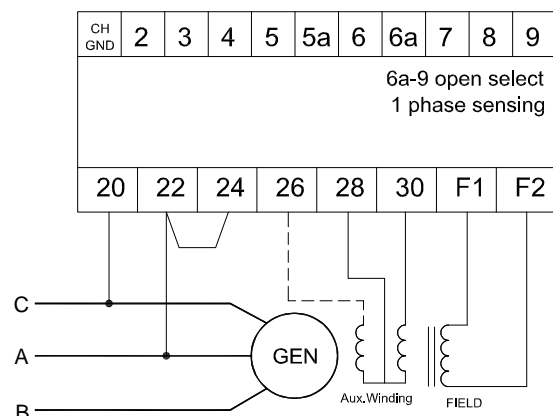

Figure 3 Auxiliary Winding  
Single Phase 28 & 30, 3 Phase 26, 28 & 30

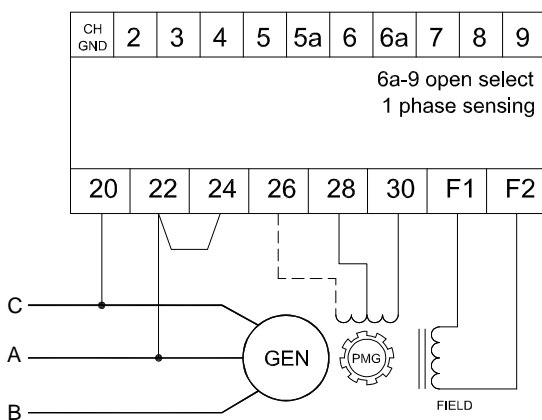

Figure 4 PMG  
Single Phase 28 & 30, 3 Phase 26, 28 & 30

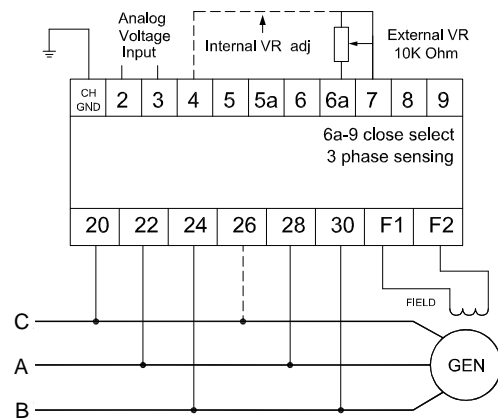

Figure 5 Voltage Adjustment  
Without External VR 4 & 7 Shorted  
With External VR (6a & 7) 4 & 7 Open

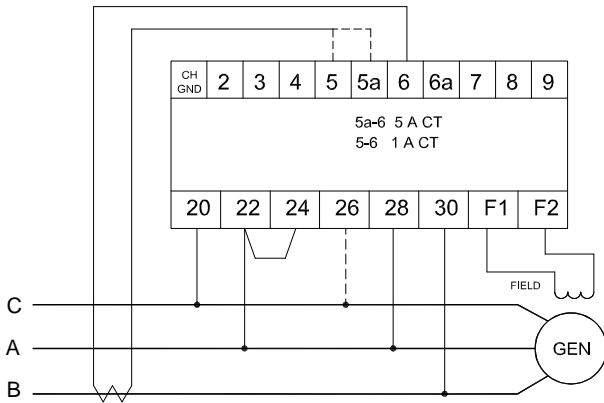

Figure 6 CT Input  
5 & 6 for 1Amps, 5a & 6 for 5Amps

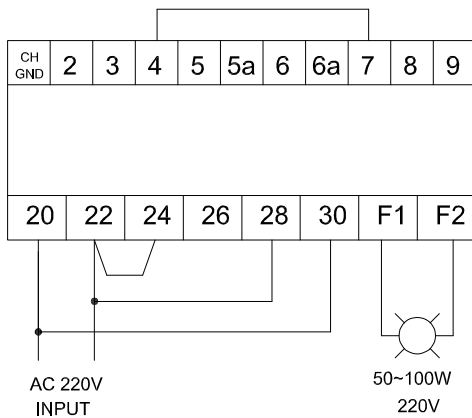

Figure 7 AVR Testing Wiring Diagram

#### ADVR63-125-12 Testing Procedure :

1. Setup ADVR63-125-12 as shown in Figure 7, and switch SW5 to OFF position.
2. Turn VOLT VR fully counterclockwise then connect to power. Lamp should be off at this time.
3. Slowly adjust VOLT VR clockwise, the lamp will illuminate, then adjust counterclockwise the lamp should turn off.
4. If lamp is constantly illuminating or unable to illuminate then change to another AVR.

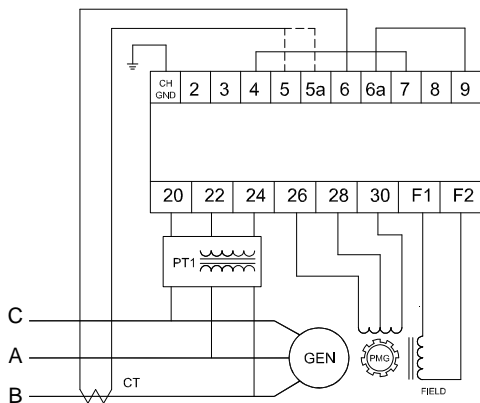

Figure 8 PMG Wiring Diagram

If generator rated voltage differs from ADVR63-125-12 sensing voltage, add PT1  
CT = 1A connect to 5 & 6, CT = 5A connect to 5a & 6

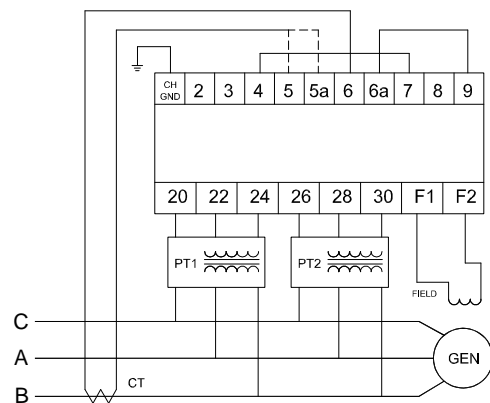

Figure 9 AUX. Wiring Diagram

If generator rated voltage differs from ADVR63-125-12 sensing voltage, add PT1  
power input voltage, add PT2  
CT = 1A connect to 5 & 6, CT = 5A connect to 5a & 6

※ Use only original supplied spare protection fuse for fuse replacement.

※ Please accept our sincere apology if any modification in performance, specification or appearance is made without prior notice.



Almost all Cat generators even connected for 480/277v are sensing at 240Volts, so be careful how you set up Voltage sensing on the ADVR63-125-12 SW -5

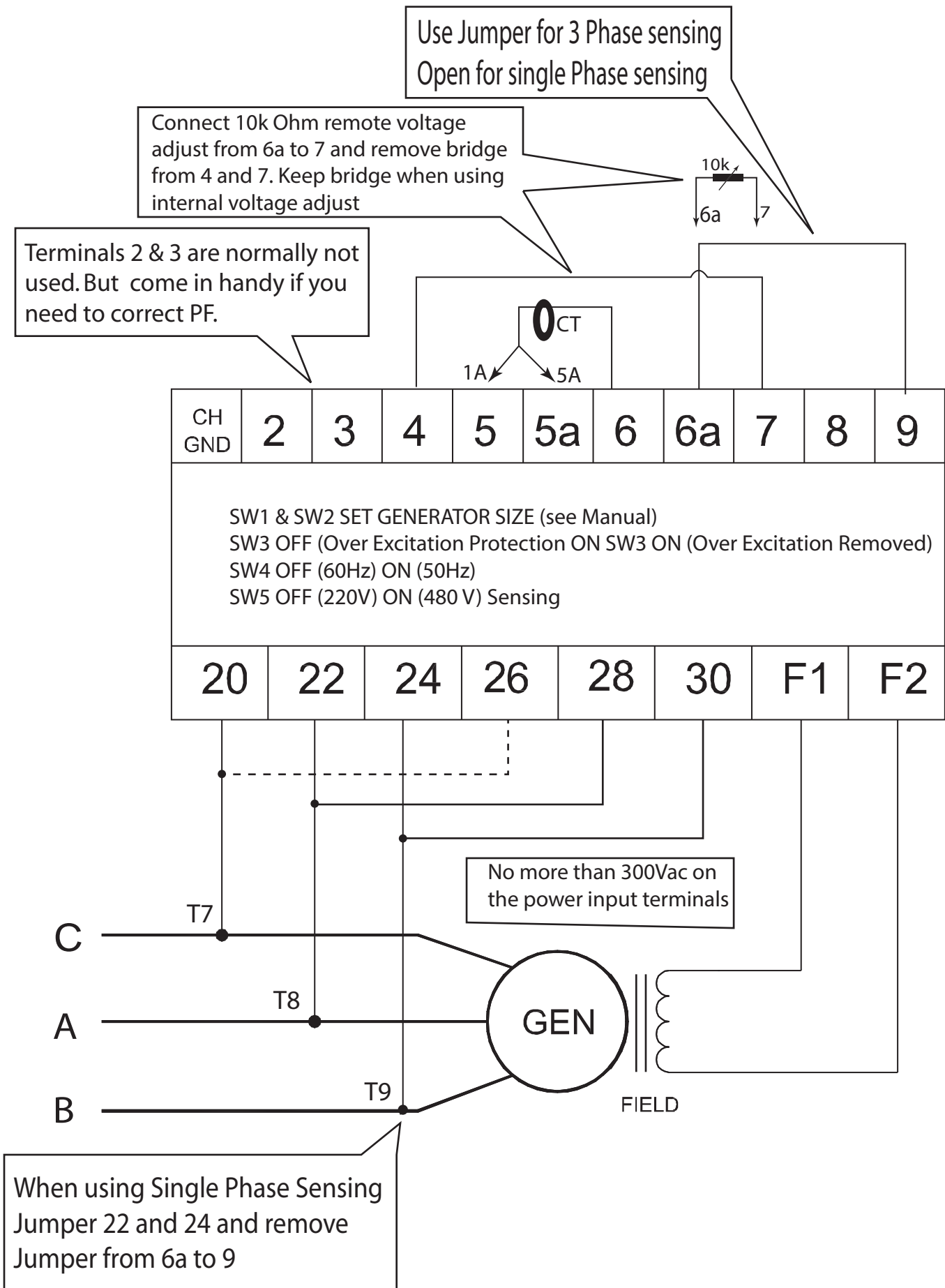

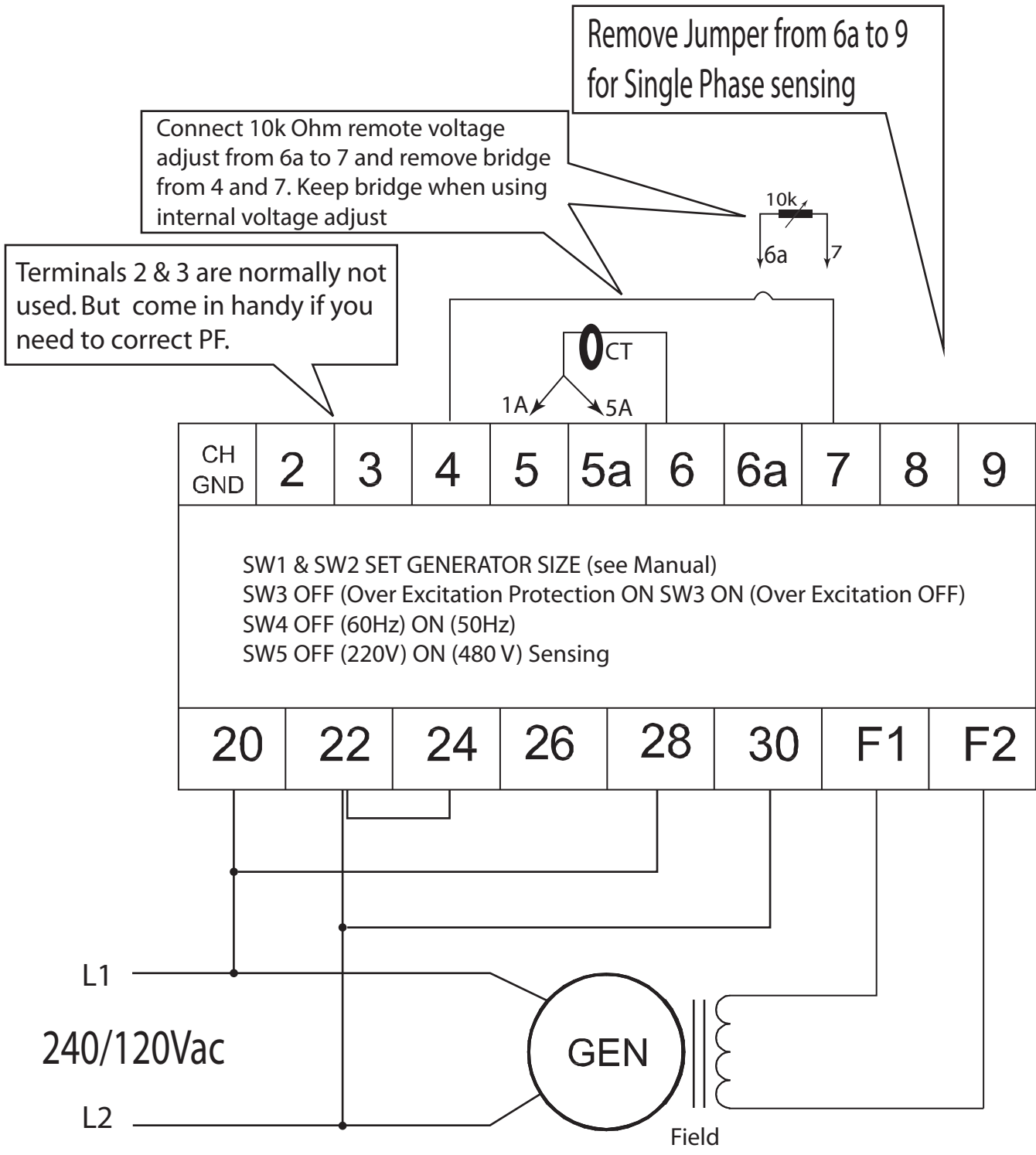

When using Single Phase Sensing Jumper 22 and 24 and remove Jumper from 6a to 9

