

# ADVR125-7F

## ***Generator Automatic Voltage Regulator User Manual***



Analog / Digital AVR featuring Excitation Current 7 Amp (Full Wave) / 5Amp (Half Wave), Selectable Full-wave or Half-wave Rectifier Output.  
Aux. Winding or Shunt powered for brush-less or brush type generators.

## SECTION 1 : SPECIFICATION

### Sensing Input (VS1, VS2) Average Readings

Voltage 90 – 540 Vac 1 phase 2 wire  
110V/220V/440V DIP switch setting  
90 – 130 Vac @ 110 Vac  
175 – 270 Vac @ 220 Vac  
350 – 540 Vac @ 440 Vac

Frequency 50/60 Hz DIP switch setting

### Power Input (P1, P2)

Voltage 60 – 300 Vac 1 phase  
Frequency 40 – 60 Hz

### External Voltage Adjustment (EXT.VR)

Max. +/- 10% @ 1 K $\Omega$  1 watt potentiometer

### Build Up Voltage

Residual voltage at AVR terminal > 5 Vac @ 25 Hz

### Soft Start Ramp Time

3 seconds +/- 10%

### Voltage Regulation

Less than +/- 0.5% ( with 4% engine governing )

### Response Time

Less than 20 ms

### EMI

Built-in electromagnetic interference filter

### Static Power Dissipation

Max. 4 watts

### Under Frequency Protection (Factory Presets)

50 Hz system knee point presets at 45 Hz  
60 Hz system knee point presets at 55 Hz

### Voltage Thermal Drift

Less than 3% from -40 to +70 °C

### Under-Frequency Knee Point Thermal Drift

Less than +/- 0.1 Hz from -40 to +70 °C

### Environment

Operating Temperature -40 to +70 °C  
Storage Temperature -40 to +85 °C  
Relative Humidity less than 95%  
Vibration 5.5Gs @ 60 Hz

### Dimensions

162.0 (L) x 118.5 (W) x 45 (H) mm  
6.38 (L) x 4.67 (W) x 1.77 (H) inch

### Weight

720 g +/- 2%  
1.58 lb +/- 2%

## Excitation Output, Resistance, O/E Voltage Protection and DIP SW Setting

	DIP SW 3	Input Voltage	Excitation Output (F+ · F-) *1	Exciter resistance	O/E Voltage Protection *2
Half Wave	ON	110 Vac	Continuous 31 Vdc 5A Max. 45 Vdc 7A 10 Sec	Min.7 Ohm, Max.100 Ohm	Excitation Voltage 35V +/-10 %
		220 Vac	Continuous 63 Vdc 5A Max. 90 Vdc 7A 10 Sec	Min.13 Ohm, Max.100 Ohm	Excitation Voltage 70V +/-10 %
Full Wave	OFF	110 Vac	Continuous 63 Vdc 7A Max. 90 Vdc 10A 10 Sec	Min.9 Ohm, Max.100 Ohm	Excitation Voltage 70V +/-10 %
		220 Vac	Continuous 125 Vdc 7A Max. 180 Vdc 10A 10 Sec	Min.18 Ohm, Max.100 Ohm	Excitation Voltage 140V +/-10 %

\*1 Fuse specification 5x20mm 8A slow blow type.

\*2 Over Excitation (O/E) output will decrease after a 10 second delay. This function can be turned OFF

## SECTION 2 : EXTERNAL APPEARANCE / DIMENSIONS / INSTALLATION DRAWING

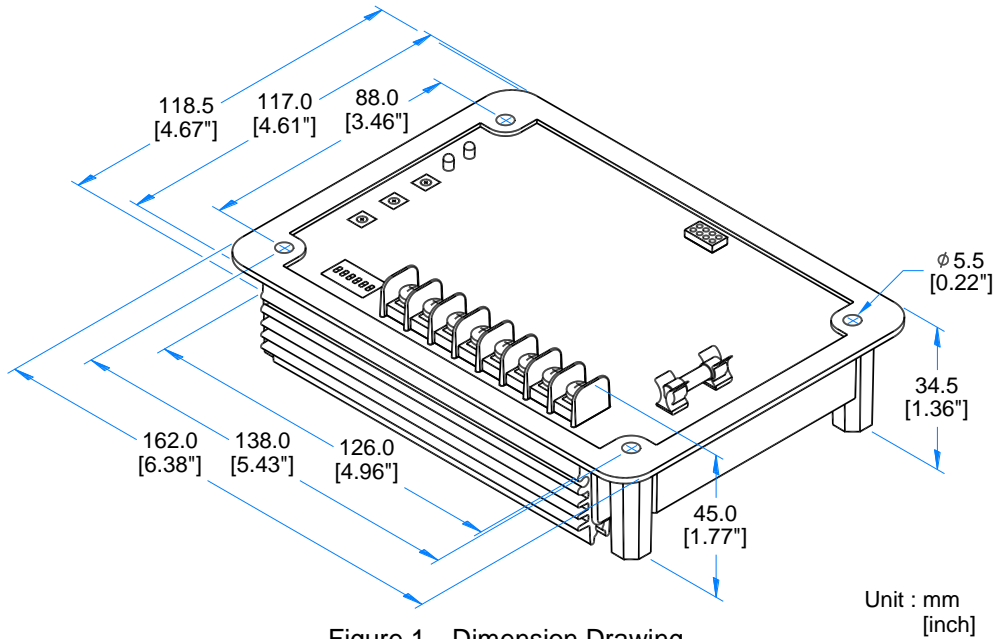

Figure 1 Dimension Drawing

## SECTION 3 : LAYOUT DESCRIPTION AND SETTINGS

### O/E : Over Excitation Voltage Protection

Turns ON when excitation voltage exceeds Over Excitation Protection setting. Excitation output will decrease if continues for more than 10 seconds.

### U/F : Under Frequency Protection LED

Turns ON when Under Frequency activated.

### UFRO : Under Frequency Roll Off Protection

50/60 Hz select via DIP SW 4

### STAB : Stability Adjustment

Generator response time select via DIP SW 6.  
In general, larger generators respond more slowly.

### VOLT : Voltage Adjustment

110V/220V/440V system select via DIP SW 1 & 2.

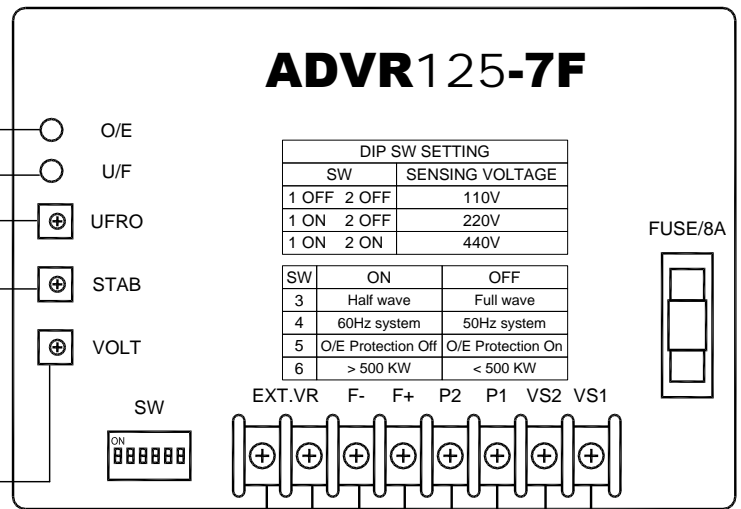

**EXT.VR : For external VR**  
Jumper when not in use

**F+ · F- : Excitation Output**  
Connect to generator Exciter Field.

**VS1, VS2 : Sensing Voltage Input**

**P1, P2 : Power Voltage Input**

**SECTION 4 : CONNECTION DIAGRAM**

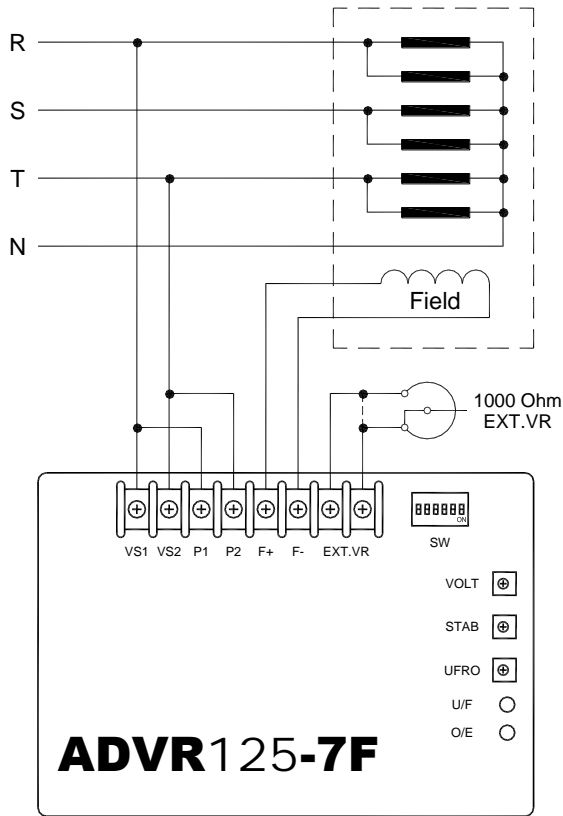

Figure 3 110/220V Wiring Diagram

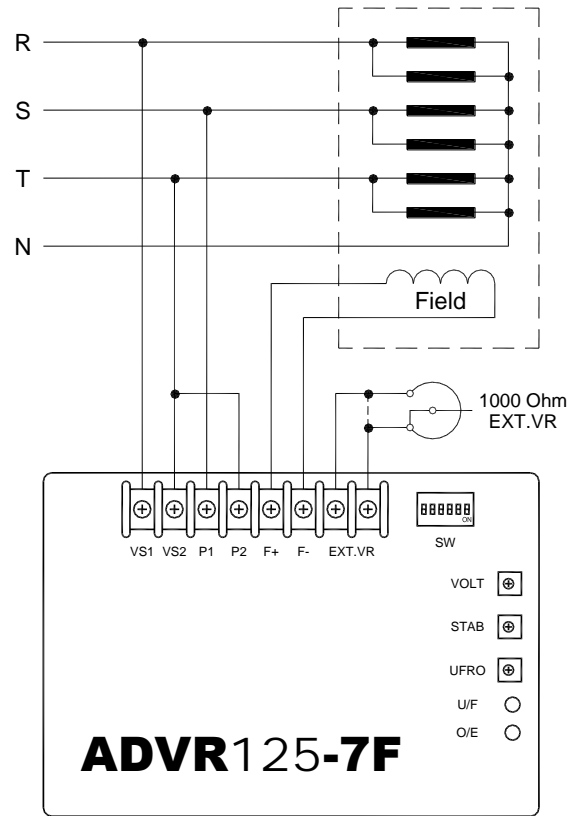

Figure 4 110/220V Wiring Diagram

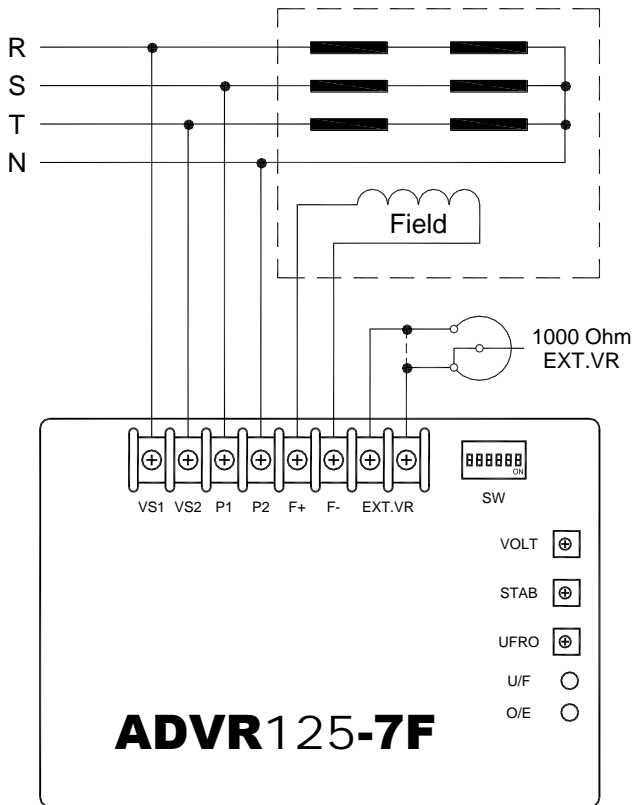

Figure 5 220/380/440V Wiring Diagram

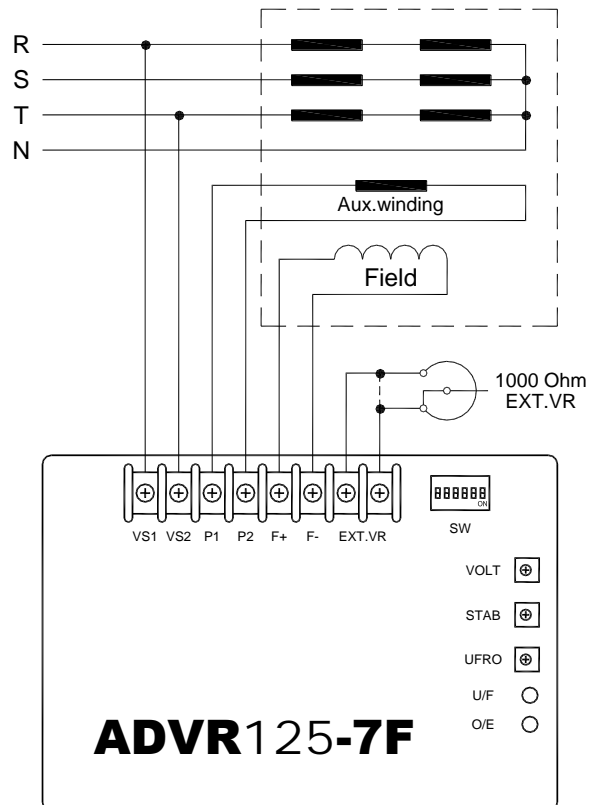

Figure 6 Aux. Wiring Diagram

---

**ATTENTION**

- 1. All voltage readings are to be taken with an average-reading voltmeter. Meggers and high-potential test equipment must not be used. Use of such equipment could damage the AVR.**
- 2. Improper setting of under-frequency protection could cause the output voltage of the unit to drop or become unstable under with changes in load. Avoid making any changes to the U/F setting unless necessary.**

- ※ Use only the replacement fuses specified in this user manual.
- ※ Appearance and specifications of products are subject to change for improvement without prior notice.